

LYNX

Cage & Bottle Washers

Model 310LX and 330LX



Ensuring efficient cleaning for all your animal care cages

The LYNX Model 310LX and 330LX Cage and Bottle Washers are heavy duty and reliable hydro-spray washers designed for ease of use, minimal maintenance, and highest cleanability of caging, bottles, debris pans, and other items used in the care of laboratory animals. These washers deliver high performance within a simplistic design. The system is provided with greater flexibility to meet today's "green" initiatives and high throughput demands. LYNX standardizes on non-proprietary parts on all equipment.

Standard Features

- Vertical Rise Sliding Door
- **Oscillating** Spray Delivery System
- Personnel Safety Features
- PLC Control System with Full Color HMI Touch Screen
- 12 Configurable Cycles
- Neutralization System
- Automatic Self-cleaning Screen
- Temperature Guarantee
- Insulated Construction
- Incoming Utility Gauges
- Interior Illumination
- SS Recirculation Piping and Components
- Non-proprietary Parts

Construction

LYNX 310LX and 330LX Cage and Bottle Washers are provided with an all stainless steel vertical rise door with a double pane glass window. Recirculated water is heated by a stainless steel steam coil to achieve guaranteed treatment temperatures. A color touch screen control panel provides a user-friendly interface for selecting, programming, and monitoring cycles. Unit is provided with a stainless steel 7½ HP treatment pump with a direct read pump pressure gauge.

Optional Features

- Pass-thru Unit
- Right or Left Hand Services
- LYNX OPTI-Wash™ Water Saving System
- High Capacity Center Header System
- House Hot Water Heat Exchanger
- Electric Heat System
- LYNX Smart-Cool™ System
- Drain Discharge Cooling - Injected
- Effluent Surge Tank
- Automatic Damper
- Exhaust Fan
- Low Steam Pressure Package
- Non-vented Vapor Condenser
- Pass-thru Door Interlock System
- Air Compressor
- Integral Data Collection System
- Printer
- Seismic Tie Down
- Detergent Dispensing Systems
- pH Neutralization Monitoring System
- Direct DI or pure water final rinse
- Barrier Wall Flange(s)

Accessories

- Cage Wash Rack
- Bottle Wash Rack
- Transfer Cart

Utilities

Electrical (E)	3-60-208/480V, 9HP
Hot Water (HW)	1" NPT, 35 PSI, 30 GPM @ 140° F ± 5° F
Cold Water (CW)*	1" NPT, 50 PSI, 40 GPM @ 50° F ± 5° F
Steam (S)	1½" NPT, 45-80 PSI, 350-600 #/Hr Flow Rate
Condensate (C)	1" NPT
Air (A)	½" NPT, 80-100 PSI, 2-4 CFM Flow Rate
Drain (D)	4" Floor Drain (<i>minimum</i>), 90 GPM Flow Rate
Vent (V)	8" ID Duct, 200 CFM, Saturated Vapor @ 190° F

*CW - Required if drain discharge cool-down package ordered

Model	Standard Chamber Size	Standard Unit Size
310LX	48" W x 32" H x 34" D	72" W x 82" H x 39" D
330LX	48" W x 32" H x 48" D	72" W x 82" H x 52.5" D

Washers can be designed to any size to meet your application requirements.

Representative Drawings

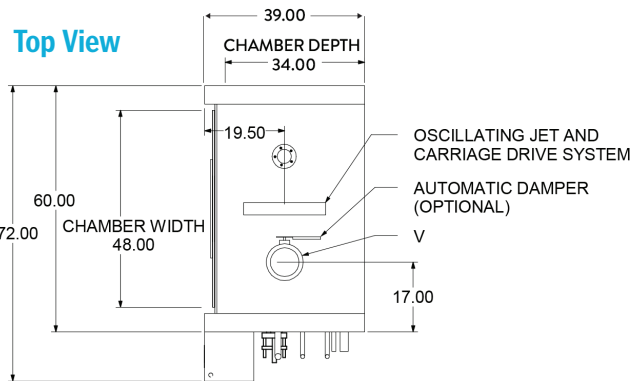
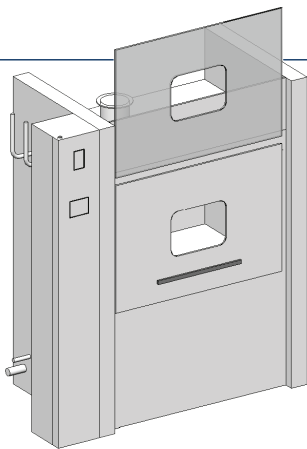

Front View

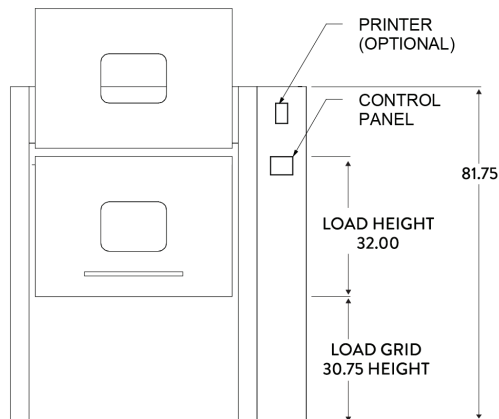

310LX Shown, contact your representative for other model drawings.

Side View

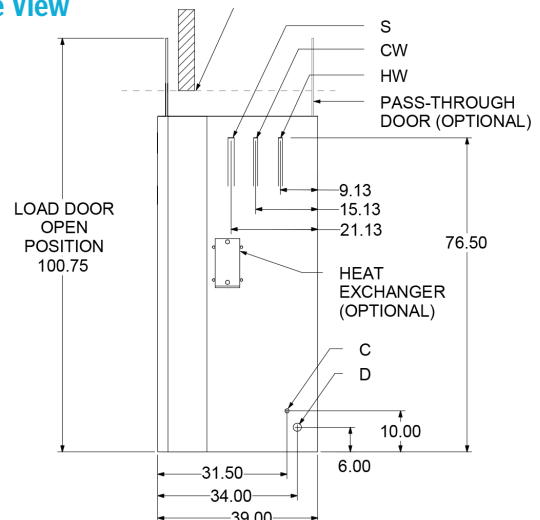

310LX_330LX Cage and Bottle Washer Sell Sheet_M1022_1.00 2021-0304