

LYNX

Cage & Rack Washers

Model 455LX



Ensuring efficient cleaning for all your animal care items

The LYNX Model 455LX (dual chamber) Cage and Rack Washers are heavy duty, large capacity reliable hydro-spray washers designed for ease of use, minimal maintenance, and highest cleanability of caging, bottles, racks, debris pans, and other items used in the care of laboratory animals. These washers deliver high performance and twice the capacity maintaining a simplistic design. The system is provided with greater flexibility to meet today's "green" initiatives and high throughput demands. LYNX standardizes on non-proprietary parts on all equipment. Pit mounting is standard.

Standard Features

- Dual Load Chambers
- Heavy-duty Hinge Doors
- Modular Construction
- Knock-down Shipment
- **Oscillating** Spray Delivery System
- Personnel Safety Features
- PLC Control System with Full Color HMI Touch Screen
- 12 Configurable Cycles
- Neutralization System
- Automatic Self-cleaning Screen
- Temperature Guarantee
- Insulated Construction
- Incoming Utility Gauges
- Interior Illumination
- SS Recirculation Piping and Components
- Non-proprietary Parts

Construction

LYNX 455LX Cage and Rack Washers are provided with heavy-duty stainless steel doors with double pane glass windows. Recirculated water is heated by a stainless steel steam coil to achieve guaranteed treatment temperatures. A color touch screen control panel provides a user-friendly interface for selecting, programming, and monitoring cycles. Unit is provided with two (2) stainless steel 10-15 HP treatment pumps with direct read pump pressure gauges.

Optional Features

- Pit or Floor Mounted
- Pass-thru Unit
- Right or Left Hand Services
- LYNX OPTI-Wash™ Water Saving System
- Re-usable Throwaway Alkaline and/or Acid Tank
- Heated Rinse Tank
- House Hot Water Heat Exchanger
- Electric Heat System
- Integral Data Collection System
- LYNX Smart-Cool™ System
- Drain Discharge Cooling - Injected/Tank
- Automatic Damper
- SS Exhaust Fan
- Low Steam Pressure Package
- Pass-thru Door Interlock System
- Air Compressor
- Printer
- Seismic Tie Down
- Detergent Dispensing Systems
- pH Neutralization System
- Feeder Bottle Washing System

Optional Features *cont*

- Integrated Pan Wash System
- Automatic Water Rack Flush System
- Split Base for Special Entry
- Port-view Door Window
- 1/3 View Glass Door
- Full View Glass Door
- 36"-54" Door Widths Available (46" wide standard)
- Active Door Seal
- Utility Enclosure Panels
- Inclined Floor Grating
- Automatic Inclined Floor Grating
- Steam Heated Dryer System
- Barrier Wall Flange(s)

Accessories

- Floor Ramps
- Modular Walls
- Bottle Wash Cart
- Universal Cage Wash Cart

Utilities

Electrical (E)	3-60-208/480V, 22-32HP
Hot Water (HW)	1½" NPT, 35 PSI, 50 GPM @ 140° F ± 5° F (40 gallon sump capacity)
Cold Water (CW)*	1½" NPT, 35 PSI, 100 GPM @ 50° F ± 5° F
Steam (S)	2" NPT, 45-80 PSI, Dynamic ± 5 PSI, 1000-1200 #/Hr Flow Rate
Condensate (C)	2" NPT
Air (A)	½" NPT, 80-100 PSI, 4-6 CFM Flow Rate
Drain (D)	(2) 12" x 12" Floor Sink with (2) 4" Floor Drain (<i>minimum</i>), 180 GPM Flow Rate
Vent (V)	12" ID Duct, 750 CFM, Saturated Vapor @ 190° F

*CW - Required if drain discharge cool-down package ordered

Model	Standard Chamber Size W x H x D	Standard Unit Size W x H x D	Opt. Door Widths	Opt. Door Heights	Opt. Chamber Lengths
455LX	Dual 46" x 85" x 141"	147" x 104" x 93"-196"	36", 48", 54"	88", 93", 96"	All 85"- 188"+

Washers can be designed to any size to meet your application requirements.

Representative Drawings

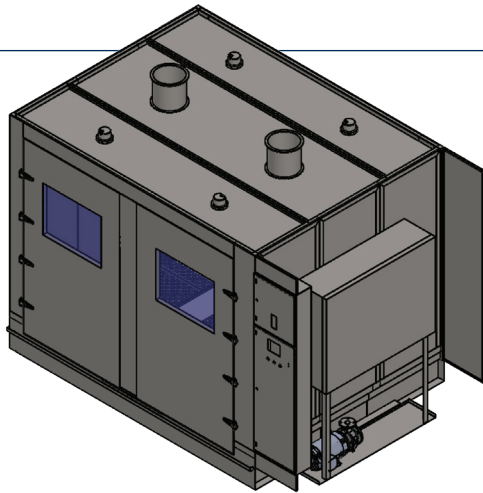

Top View

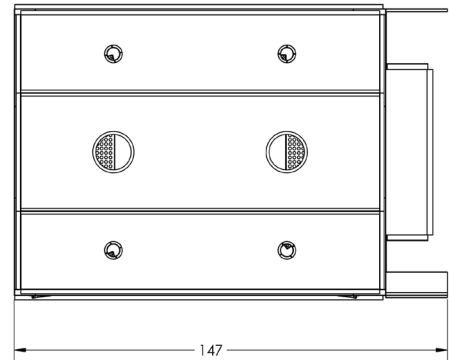

Front View

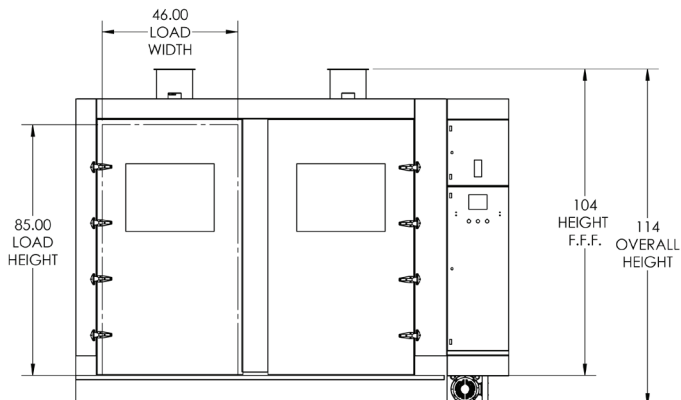

Side View

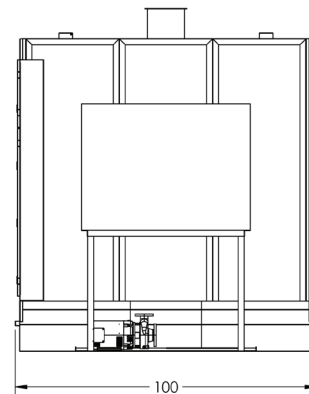

455LX Cage and Rack Washer Sell Sheet_M1039_1.00 2021-0318