

LYNX

# Tunnel Washers

## Model 536LX

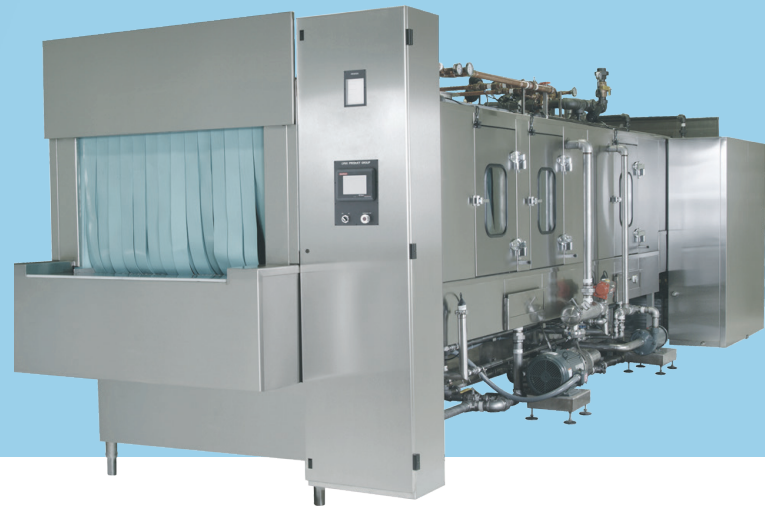

### Ensuring efficient cleaning for all your animal care items

The LYNX 536LX Cage Tunnel Washer is a heavy-duty conveyorized hydro-spray washer designed to clean and dry caging, lids, feeder bowls, bottles and other items used in the care of laboratory animals. The 500 Series Washers are available in 7 different belt widths, maximizing cage processing time and efforts. Flexible design is available with a wide array of options and configurability to meet customer's specific requirements. LYNX standardizes use of non-proprietary parts on all equipment.

#### Standard Features

- Splash Proof Access Doors
- 2-10 FPM Conveyor Drive Motor
- Integral Unitized Construction
- Removable Spray Headers
- Flat Wire Conveyor Belt
- Personnel Safety Features
- Automatic Control System
- PLC Control System with Full Color HMI Touch Screen
- Configurable Cycles
- Automatic Water Level Control
- Neutralization System
- Drawer Debris Screens
- 180° F Recirculated Temperature Guarantee
- Insulated Construction
- Hydraulic Hold-down System
- Incoming Utility Gauges
- SS Recirculation Piping and Components
- Non-proprietary Parts
- Automatic Tank Draining System
- De-scaling Cycle
- Final Rinse Modulating Steam Valve
- Automatic Self Cleaning Screen (wash)

#### Construction

LYNX 536LX Tunnel Washers are built to perform under the most rugged and aggressive environments with robust design and construction. The durable stainless steel belt is manufactured to withstand the weight and impact of heavy bottle wash racks and other large objects requiring

processing. The system is designed to minimize water usage by reusing 100% of final rinse water in the prewash and tank top-off process. Recirculated water is heated by stainless steel steam coils to maintain and achieve guaranteed treatment temperatures. A color touch screen control panel provides a user-friendly interface for selecting, programming, and monitoring cycles.

#### Optional Features

- Right or Left Hand Services
- LYNX OPTI-Flow™ Water and Energy Saving System
- Automatic Self Cleaning Screen (rinse)
- Discharge Roller Conveyors
- Integral Data Collection System
- Automatic Drain Discharge Cooldown System
- Low Steam Pressure Package
- Air Compressor
- Printer
- 7' Double Blower Drying System
- Seismic Tie Down
- Detergent Dispensing Systems
- pH Neutralization System
- Bedding Dispenser Controls
- Added Load End Extensions
- Integrated Bedding Dump Stations - Garb-el, Vacuum, Garbage Tote or Can
- Interior Illumination
- Barrier Wall Flange(s)

#### Accessories

- Modular Walls

## Utilities

<b>Electrical (E)</b>	3-60-208/480V, 26HP
<b>Hot Water (HW)</b>	1½" NPT, 35-60 PSI, 30-50 GPM @ 140° F ± 5° F ( <i>fills only</i> ), HW 10-12 GPM continuous
<b>Cold Water (CW)*</b>	1½" NPT, 35-60 PSI, 35 GPM @ 50° F ± 5° F
<b>Steam (S)</b>	2" NPT, 45-80 PSI, Dynamic ± 5 PSI, 1800 #/Hr Flow Rate
<b>Steam (S2)</b>	2" NPT, 45-80 PSI, Dynamic ± 5 PSI, 1000 #/Hr Flow Rate
<b>Condensate (C)</b>	1" NPT (2 required)
<b>Air (A)</b>	½" NPT, 100-125 PSI, 1-2 CFM Flow Rate
<b>Drain (D)</b>	12" x 12" Floor Sink with 4" Floor Drain, 50 GPM Flow Rate ( <i>2 required</i> )
<b>Vent (V)</b>	18" ID Duct, 2200 CFM, 2-3" WC SP, Saturated Vapor @ 180° F

\*S2 - Required if optional dryer package is ordered \*\*CW - Required if drain discharge cool-down package ordered

Model	Standard Tunnel Opening - W x H	Standard Unit Size* W x H	Washer Lengths*	Standard Belt Width	Opt. Tunnel Heights*
536LX	37" x 25"	73" x 85"	15'-24' (with dryer)	36"	18", 25", 36"

\*Washers can be designed to any size to meet your application requirements. Overall size may vary depending on options.

## Representative Drawings

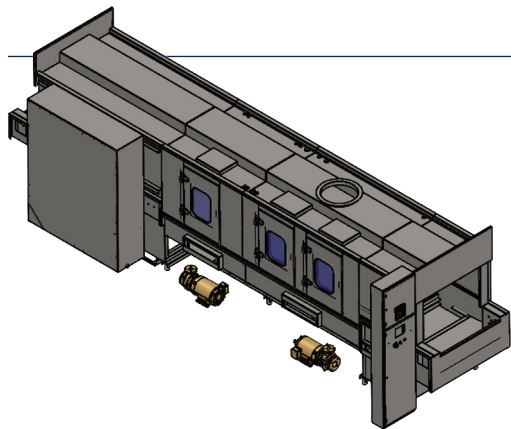

Top View

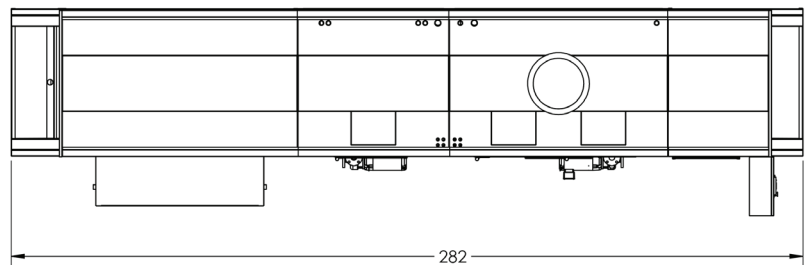

Front View

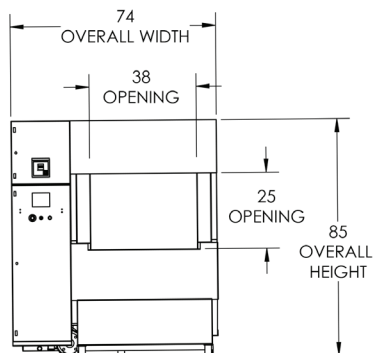

Side View

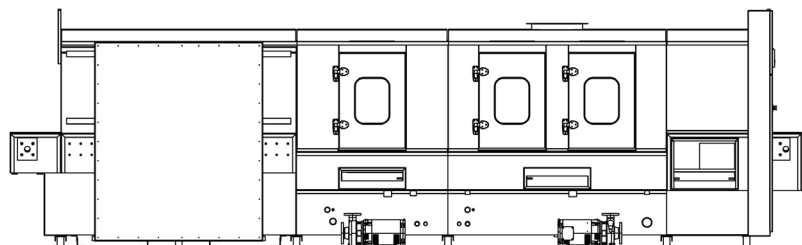

536LX Tunnel Washer Sell Sheet\_M1051\_1.00 2021-0326